



date \_\_\_\_\_  
 customer \_\_\_\_\_  
 project \_\_\_\_\_  
 quantity \_\_\_\_\_

# DOWNITO 70 DEEP

Recessed Down Light

Downito® 70 Deep is a compact 20W LED downlight for accent lighting, that allows a wide variety of lighting applications in retail (CRI 90), hospitality, residential, offices (UGR<19). The latest technology 35°, 50° and 70° active reflectors, designed by Bartenbach, enable light distribution with a unique precision, high performance up to 89 lm/W and a 1000 lm luminous flux. The passive reflectors in white, black, chrome, gold and RAL under request, give the possibility to play with different color luminaires. Downito® 70 is available in 3500K and can be controlled by 0-10V systems. Compact, precise and high-performance design, the perfect combination for your lighting projects



Family	Model / Wattage	IP Type	Finish	Beam / Lumens	CRI / Color temp	Diffuser	Passive Reflector	Driver
DOWNITO 70	7115 2 x 10W	5 IP20 6 IP40 - Diffuser	0 silver	0 35 deg - 1389 - 1531lm	90/2K7 2700K 90/3K 3000K 90/3K5 3500K 90/4K 4000K	C *clear M *milky	C chrome	U Universal 0-10V
			2 black	1 50 deg - 1576 - 1737lm			B black	
			3 white	2 70 deg - 1607 - 1771lm			W white	
							G gold	

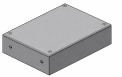

Notes: (\*) IP40 only

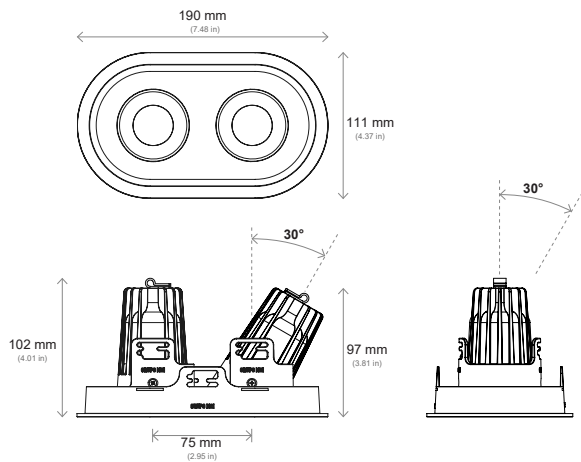

7115