



date	
customer	
project	
quantity	

DOWNITO 70 DEEP

Recessed Down Light

Downito® 70 Deep is a compact 20W LED downlight for accent lighting, that allows a wide variety of outdoor lighting applications in retail (CRI 90), hospitality, residential, offices (UGR<19) and (IP65). The latest technology 35°, 50° and 70° active reflectors, designed by Bartenbach, enable light distribution with a unique precision, high performance up to 89 lm/W and a 1000 lm luminous flux. The passive reflectors in white, black, chrome, gold and RAL under request, give the possibility to play with different color luminaires. Downito® 70 is available in 3500K and can be controlled by 0-10V systems. Compact, precise and high-performance design, the perfect combination for your lighting projects



Family	Model / Wattage	IP Type	Finish	Beam / Lumens	CRI / Color temp	Diffuser	Passive Reflector	Driver	Input voltage
DOWNITO 70									
 N, A	7115 2 x 10W	8 IP65 - Diffuser	0 silver	0 35 deg - 1389 - 1531lm	90/3K5 3500K	C *clear M *milky	C chrome	N non dim A 0 - 10V N1 non dim A1 0 - 10V	120 120V input 277 277V input
			2 black	1 50 deg - 1576 - 1737lm			B black		
			3 white	2 70 deg - 1607 - 1771lm			W white		
							G gold		

example...

Family	Model / Wattage	IP Type	Finish	Beam / Lumens	CRI / Color temp	Diffuser	PassiveReflector	Driver	Input
DOWNITO 70	7115	8	0	0	90/3K5	M	C	A1	120

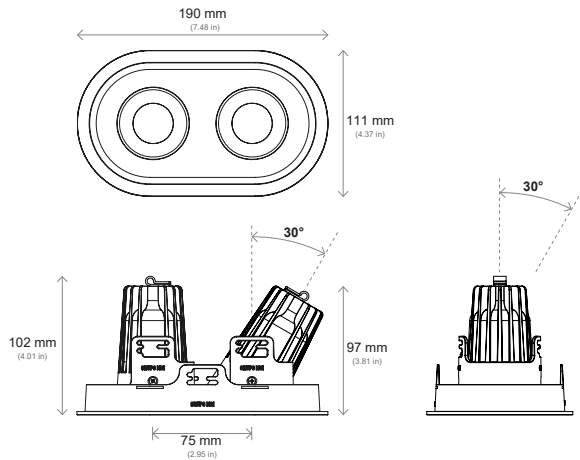

7115